

Signals and Signal Processing

- Signals play an important role in our daily life
- A signal is a function of independent variables such as time, distance, position, temperature, and pressure
- Some examples of typical signals are shown next

Examples of Typical Signals

- **Speech and music signals** - Represent **air pressure** as a function of **time** at a point in space
- **Waveform of the speech signal “I like digital signal processing”** is shown below

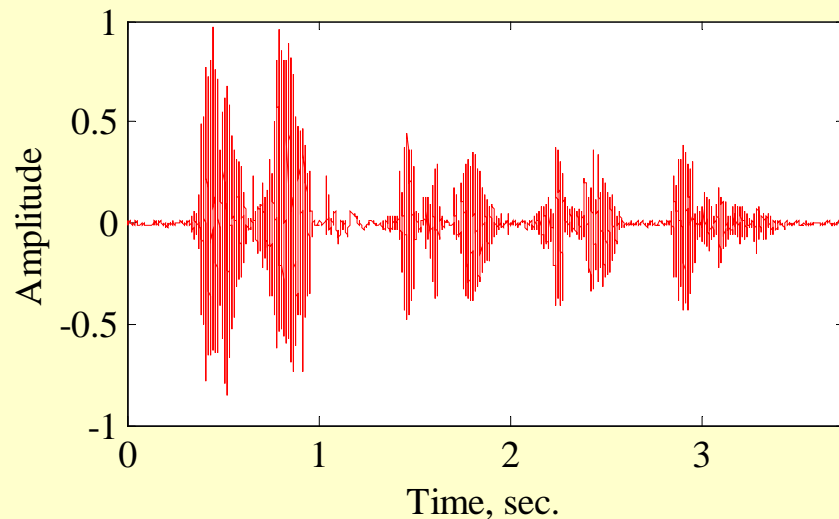

Examples of Typical Signals

- **Electrocardiography (ECG) Signal** - Represents the electrical activity of the heart
- A typical ECG signal is shown below



Examples of Typical Signals

- The ECG trace is a periodic waveform
- One period of the waveform shown below represents one cycle of the blood transfer process from the heart to the arteries

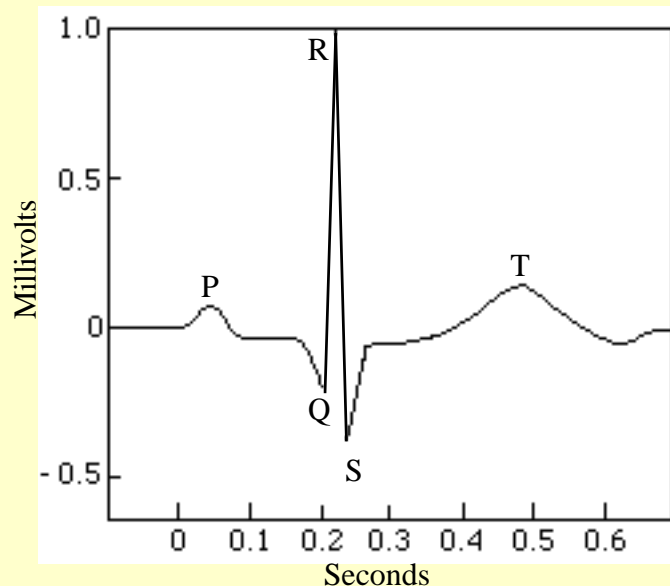

Examples of Typical Signals

- **Electroencephalogram (EEG) Signals** -
Represent the electrical activity caused by the random firings of billions of neurons in the brain

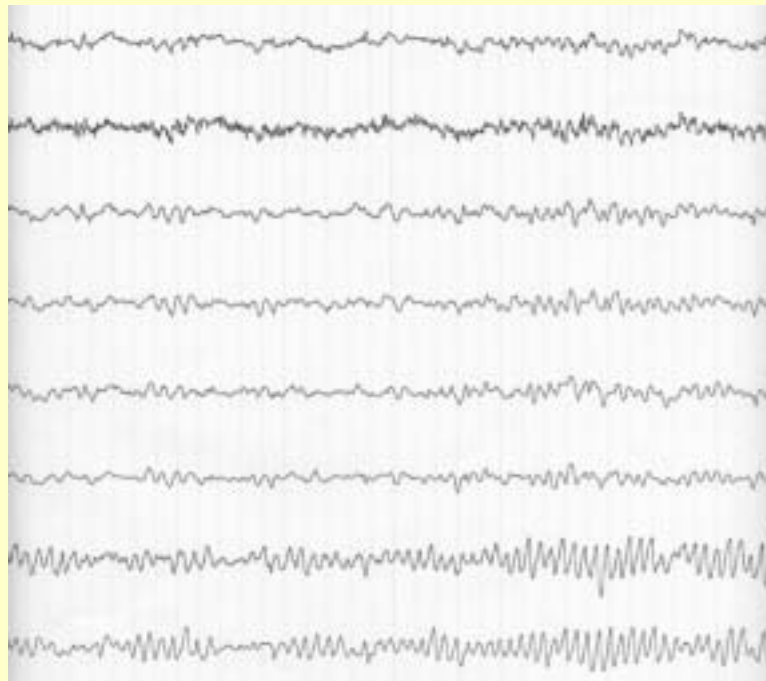

Examples of Typical Signals

- **Seismic Signals** - Caused by the movement of rocks resulting from an earthquake, a volcanic eruption, or an underground explosion
- The ground movement generates 3 types of elastic waves that propagate through the body of the earth in all directions from the source of movement

Examples of Typical Signals

- Typical seismograph record

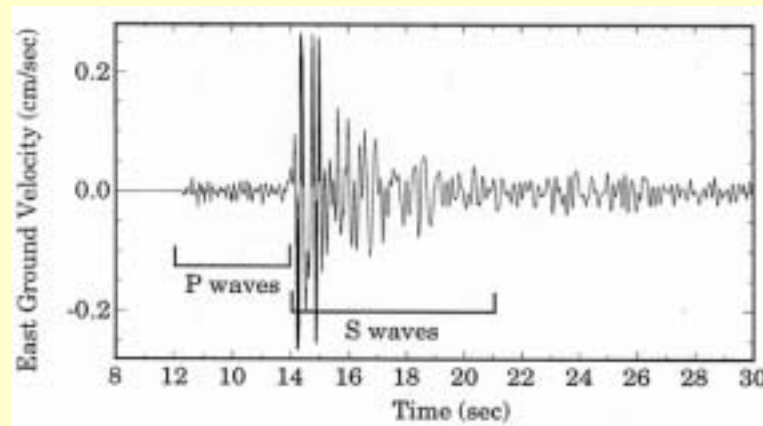
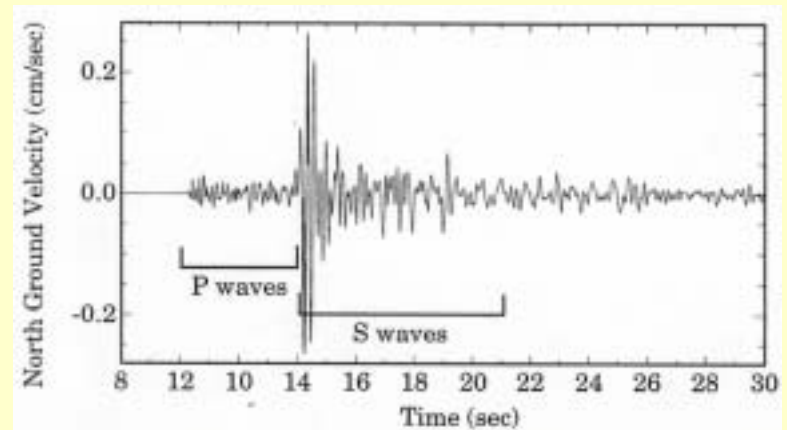
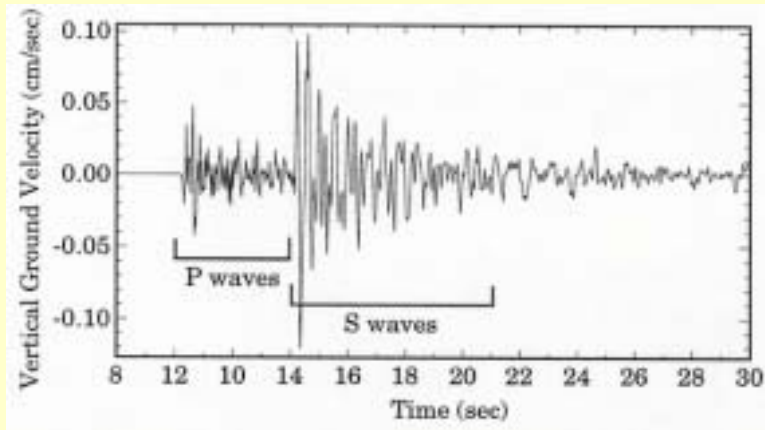

Examples of Typical Signals

- Black-and-white picture - Represents light intensity as a function of two spatial coordinates



$I(x,y)$

Examples of Typical Signals

- **Video signals** - Consists of a sequence of images, called **frames**, and is a function of 3 variables: 2 **spatial coordinates** and **time**



Frame 1



Frame 3



Frame 5



Video

Click on the video

Signals and Signal Processing

- Most signals we encounter are generated naturally
- However, a signal can also be generated synthetically or by a computer

Signals and Signal Processing

- A signal carries information
- Objective of signal processing: Extract the useful information carried by the signal
- Method information extraction: Depends on the type of signal and the nature of the information being carried by the signal
- This course is concerned with the discrete-time representation of signals and their discrete-time processing

Characterization and Classification of Signals

- **Types of signal:** Depends on the nature of the independent variables and the value of the function defining the signal
- For example, the independent variables can be continuous or discrete
- Likewise, the signal can be a continuous or discrete function of the independent variables

Characterization and Classification of Signals

- Moreover, the signal can be either a real-valued function or a complex-valued function
- A signal generated by a single source is called a scalar signal
- A signal generated by multiple sources is called a vector signal or a multichannel signal

Characterization and Classification of Signals

- A one-dimensional (1-D) signal is a function of a single independent variable
- A multidimensional (M-D) signal is a function of more than one independent variables
- The speech signal is an example of a 1-D signal where the independent variable is time

Characterization and Classification of Signals

- An image signal, such as a photograph, is an example of a 2-D signal where the 2 independent variables are the 2 spatial variables
- A color image signal is composed of three 2-D signals representing the three primary colors: red, green and blue (RGB)

Characterization and Classification of Signals

- The 3 color components of a color image are shown below

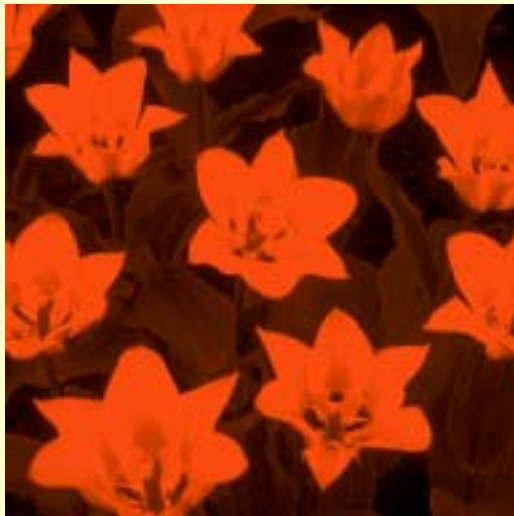

Characterization and Classification of Signals

- The full color image obtained by displaying the previous 3 color components is shown below



Characterization and Classification of Signals

- Each frame of a black-and-white digital video signal is a 2-D image signal that is a function of 2 discrete spatial variables, with each frame occurring at discrete instants of time
- Hence, black-and-white digital video signal can be considered as an example of a 3-D signal where the 3 independent variables are the 2 spatial variables and time

Characterization and Classification of Signals

- A color video signal is a 3-channel signal composed of three 3-D signals representing the three primary colors: red, green and blue (RGB)
- For transmission purposes, the RGB television signal is transformed into another type of 3-channel signal composed of a luminance component and 2 chrominance components

Characterization and Classification of Signals

- For a 1-D signal, the independent variable is usually labeled as time
- If the independent variable is continuous, the signal is called a continuous-time signal
- If the independent variable is discrete, the signal is called a discrete-time signal

Characterization and Classification of Signals

- A continuous-time signal is defined at every instant of time
- A discrete-time signal is defined at discrete instants of time, and hence, it is a sequence of numbers
- A continuous-time signal with a continuous amplitude is usually called an analog signal
- A speech signal is an example of an analog signal

Characterization and Classification of Signals

- A discrete-time signal with discrete-valued amplitudes represented by a finite number of digits is referred to as the digital signal
- An example of a digital signal is the digitized music signal stored in a CD-ROM disk
- A discrete-time signal with continuous-valued amplitudes is called a sampled-data signal

Characterization and Classification of Signals

- A digital signal is thus a quantized sampled-data signal
- A continuous-time signal with discrete-value amplitudes is usually called a quantized boxcar signal
- The figure in the next slide illustrates the 4 types of signals

Characterization and Classification of Signals

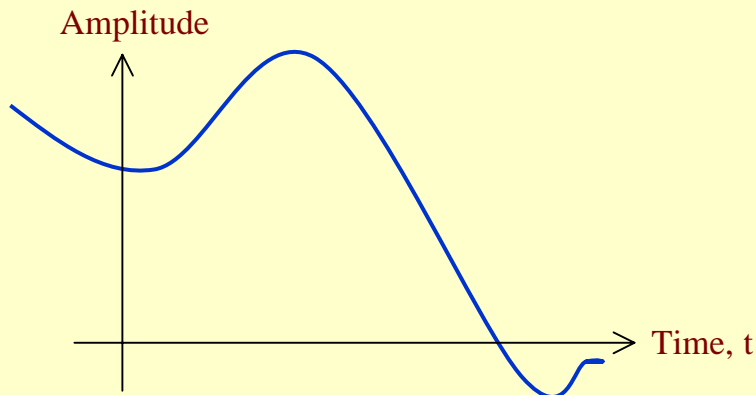

A continuous-time signal

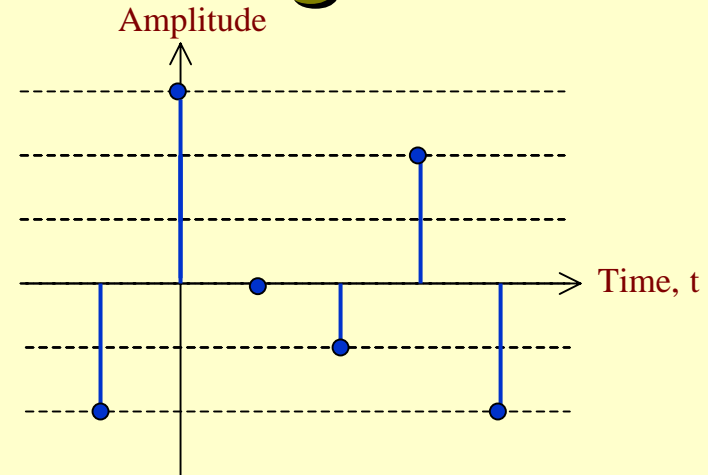

A digital signal

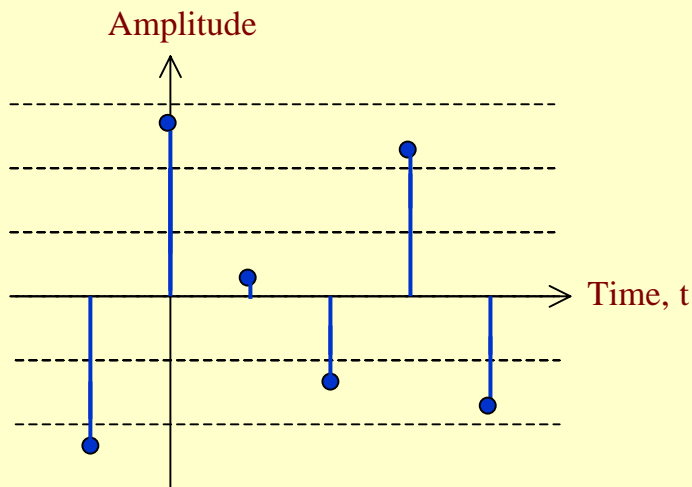

A sampled - data signal

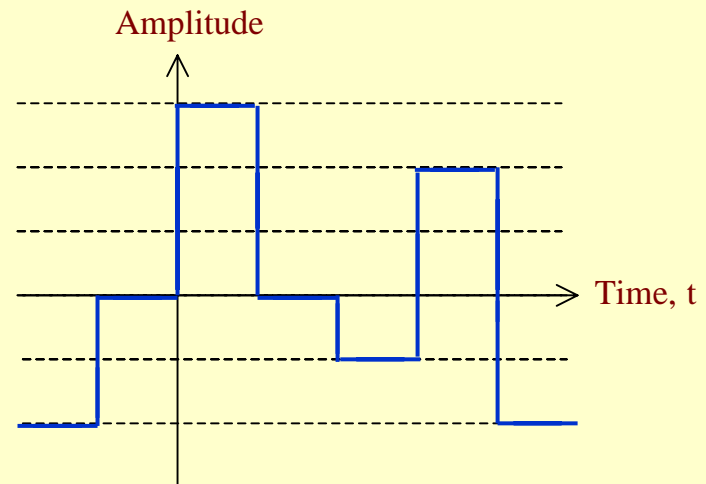

A quantized boxcar signal

Characterization and Classification of Signals

- The functional dependence of a signal in its mathematical representation is often explicitly shown
- For a continuous-time 1-D signal, the continuous independent variable is usually denoted by t
- For example, $u(t)$ represents a continuous-time 1-D signal

Characterization and Classification of Signals

- For a discrete-time 1-D signal, the discrete independent variable is usually denoted by n
- For example, $\{v[n]\}$ represents a discrete-time 1-D signal
- Each member, $v[n]$, of a discrete-time signal is called a sample

Characterization and Classification of Signals

- In many applications, a discrete-time signal is generated by **sampling** a parent continuous-time signal at **uniform intervals** of time
- If the discrete instants of time at which a discrete-time signal is defined are **uniformly spaced**, the independent discrete variable n can be normalized to assume **integer values**

Characterization and Classification of Signals

- In the case of a continuous-time 2-D signal, the 2 independent variables are the spatial coordinates, usually denoted by x and y
- For example, the intensity of a black-and-white image at location (x,y) can be expressed as $u(x,y)$

Characterization and Classification of Signals

- On the other hand, a digitized image is a 2-D discrete-time signal, and its 2 independent variables are discretized spatial variables, often denoted by m and n
- Thus, a digitized image can be represented as $v[m,n]$
- A black-and-white video signal is a 3-D signal and can be represented as $u(x,y,t)$

Characterization and Classification of Signals

- A color video signal is a vector signal composed of 3 signals representing the 3 primary colors: red, green, and blue

$$\mathbf{u}(x, y, t) = \begin{bmatrix} r(x, y, t) \\ g(x, y, t) \\ b(x, y, t) \end{bmatrix}$$

Characterization and Classification of Signals

- A signal that can be uniquely determined by a well-defined process, such as a mathematical expression or rule, or table look-up, is called a deterministic signal
- A signal that is generated in a random fashion and cannot be predicted ahead of time is called a random signal

Typical Signal Processing Applications

- Most signal processing operations in the case of analog signals are carried out in the time-domain
- In the case of discrete-time signals, both time-domain or frequency-domain operations are usually employed

Elementary Time-Domain Operations

- Three most basic time-domain signal operations are scaling, delay, and addition
- Scaling is simply the multiplication of a signal either by a positive or negative constant
- In the case of analog signals, the operation is usually called **amplification** if the magnitude of the multiplying constant, called **gain**, is greater than 1

Elementary Time-Domain Operations

- If the magnitude of the multiplying constant is less than 1, the operation is called attenuation
- If $x(t)$ is an analog signal that is scaled by a constant α , then the scaling operation generates a signal $y(t) = \alpha x(t)$
- Two other elementary operations are integration and differentiation

Elementary Time-Domain Operations

- The integration of an analog signal $x(t)$ generates a signal

$$y(t) = \int_{-\infty}^t x(\tau) d\tau$$

- The differentiation of an analog signal $x(t)$ generates a signal

$$w(t) = \frac{dx(t)}{dt}$$

Elementary Time-Domain Operations

- The delay operation generates a signal that is a delayed replica of the original signal

- For an analog signal $x(t)$,

$$y(t) = x(t - t_0)$$

is the signal obtained by delaying $x(t)$ by the amount of time t_0 which is assumed to be a positive number

- If t_0 is negative, then it is an advance operation

Elementary Time-Domain Operations

- Many applications require operations involving two or more signals to generate a new signal
- For example,

$$y(t) = x_1(t) + x_2(t) + x_3(t)$$

is the signal generated by the addition of the three analog signals, $x_1(t)$, $x_2(t)$, and $x_3(t)$

Elementary Time-Domain Operations

- The product of 2 signals, $x_1(t)$ and $x_2(t)$, generates a signal

$$y(t) = x_1(t) \cdot x_2(t)$$

- The elementary operations discussed so far are also carried out on discrete-time signals
- More complex operations are implemented by combining two or more elementary operations

Filtering

- Filtering is one of the most widely used complex signal processing operations
- The system implementing this operation is called a filter
- A filter passes certain frequency components without any distortion and blocks other frequency components

Filtering

- The range of frequencies that is allowed to pass through the filter is called the passband, and the range of frequencies that is blocked by the filter is called the stopband
- In most cases, the filtering operation for analog signals is linear

Filtering

- The filtering operation of a linear analog filter is described by the **convolution integral**

$$y(t) = \int_{-\infty}^{\infty} h(t - \tau)x(\tau)d\tau$$

where $x(t)$ is the **input signal**, $y(t)$ is the **output** of the filter, and $h(t)$ is the **impulse response** of the filter

Filtering

- A lowpass filter passes all low-frequency components below a certain specified frequency f_c , called the cutoff frequency, and blocks all high-frequency components above f_c
- A highpass filter passes all high-frequency components a certain cutoff frequency f_c and blocks all low-frequency components below

Filtering

- A bandpass filter passes all frequency components between 2 cutoff frequencies, f_{c1} and f_{c2} , where $f_{c1} < f_{c2}$, and blocks all frequency components below the frequency f_{c1} and above the frequency f_{c2}
- A bandstop filter blocks all frequency components between 2 cutoff frequencies, f_{c1} and f_{c2} , where $f_{c1} < f_{c2}$, and passes all frequency components below the frequency f_{c1} and above the frequency f_{c2}

Filtering

- Figures below illustrate the lowpass filtering of an input signal composed of 3 sinusoidal components of frequencies 50 Hz, 110 Hz, and 210 Hz

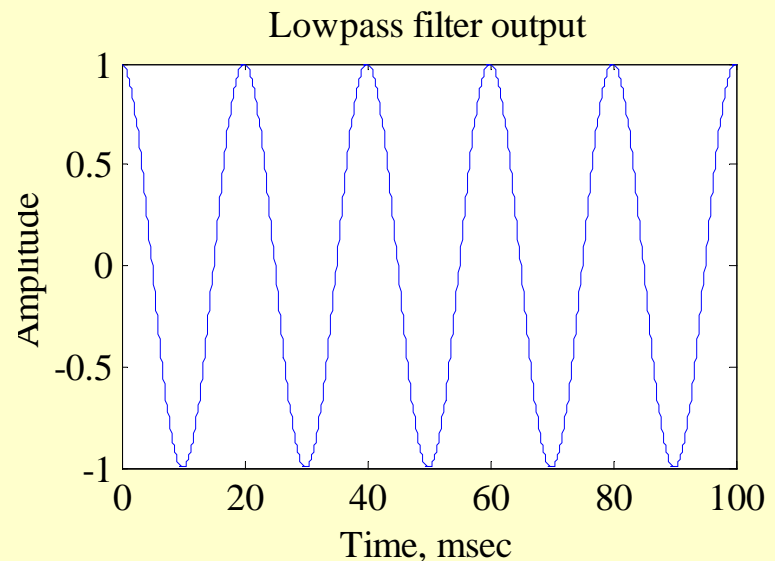
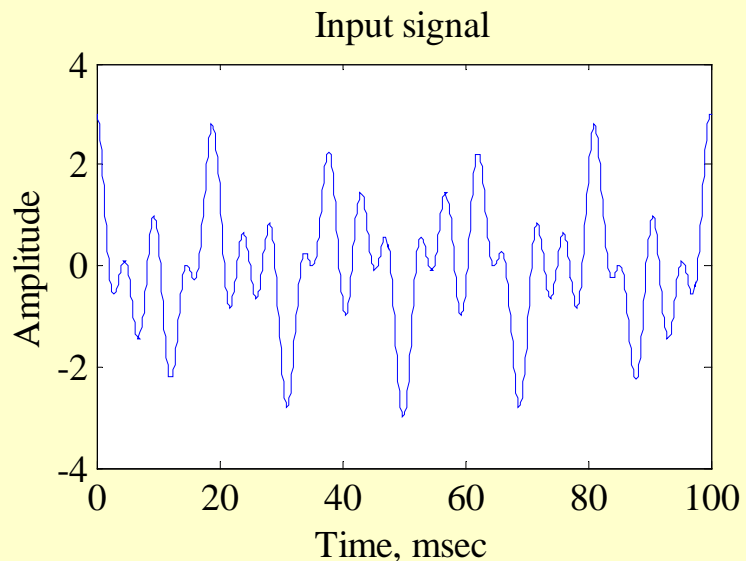

Filtering

- Figures below illustrate highpass and bandpass filtering of the same input signal

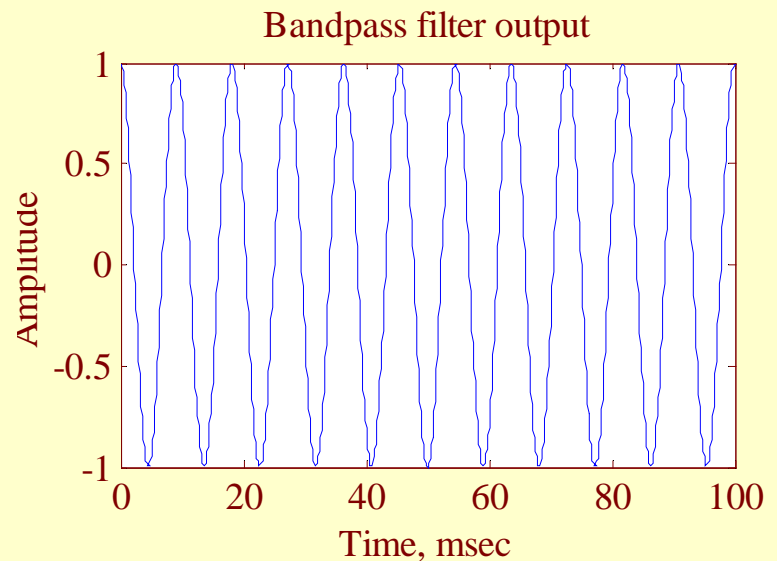
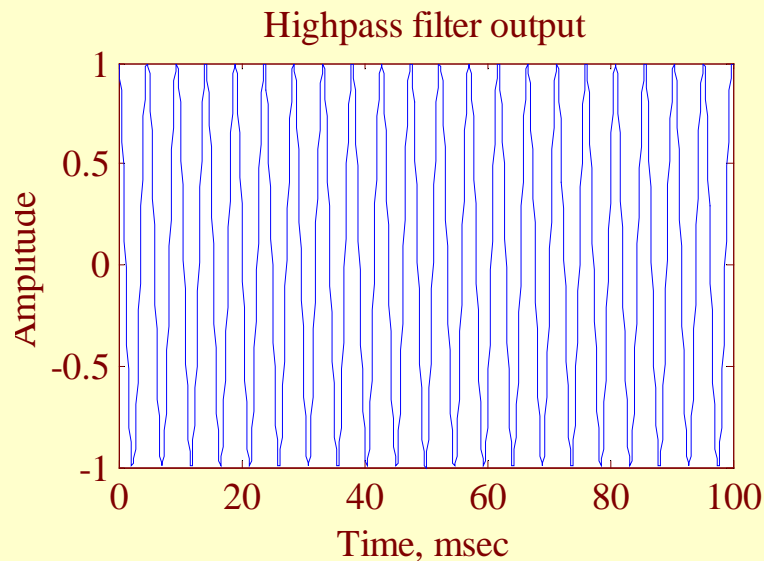

Filtering

- There are various other types of filters
- A filter blocking a single frequency component is called a notch filter
- A multiband filter has more than one passband and more than one stopband
- A comb filter blocks frequencies that are integral multiples of a low frequency

Filtering

- In many applications the desired signal occupies a low-frequency band from dc to some frequency f_L Hz, and gets corrupted by a high-frequency noise with frequency components above f_H Hz with $f_H > f_L$
- In such cases, the desired signal can be recovered from the noise-corrupted signal by passing the latter through a lowpass filter with a cutoff frequency f_c where $f_L < f_c < f_H$

Filtering

- A common source of noise is power lines radiating electric and magnetic fields
- The noise generated by power lines appears as a 60-Hz sinusoidal signal corrupting the desired signal and can be removed by passing the corrupted signal through a notch filter with a notch frequency at 60 Hz

Generation of Complex Signals

- A signal can be real-valued or complex-valued
- For convenience, the former is usually called a real signal while the latter is called a complex signal
- A complex signal can be generated from a real signal by employing a Hilbert transformer

Generation of Complex Signals

- The impulse response of a Hilbert transformer is given by

$$h_{HT}(t) = \frac{1}{\pi t}$$

- Consider a real signal $x(t)$ with a continuous-time Fourier transform (CTFT) $X(j\Omega)$ given by

$$X(j\Omega) = \int_{-\infty}^{\infty} x(t) e^{-j\Omega t} dt$$

Generation of Complex Signals

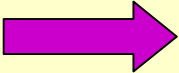
- $X(j\Omega)$ is called the spectrum of $x(t)$
- The magnitude spectrum of a real signal exhibits even symmetry with respect to ω while the phase spectrum exhibits odd symmetry
-  The spectrum $X(j\Omega)$ of a real signal $x(t)$ contains both positive and negative frequencies

Generation of Complex Signals

- Thus we can write

$$X(j\Omega) = X_p(j\Omega) + j X_n(j\Omega)$$

where $X_p(j\Omega)$ is the portion of $X(j\Omega)$ occupying the positive frequency range and $X_n(j\Omega)$ is the portion of $X(j\Omega)$ occupying the negative frequency range

Generation of Complex Signals

- If $x(t)$ is passed through a Hilbert transformer, its output $y(t)$ is given by:

$$y(t) = \int_{-\infty}^{\infty} h_{HT}(t - \tau)x(\tau)d\tau$$

- The spectrum $Y(j\Omega)$ of $y(t)$ is given by the product of the CTFTs of $h_{HT}(t)$ and $x(t)$

Generation of Complex Signals

- The CTFT $H_{HT}(j\Omega)$ of $h_{HT}(t)$ is given by

$$H_{HT}(j\Omega) = \begin{cases} -j, & \Omega > 0 \\ j, & \Omega < 0 \end{cases}$$

- Therefore

$$\begin{aligned} Y(j\Omega) &= H_{HT}(j\Omega)X(j\Omega) \\ &= -jX_p(j\Omega) + jX_n(j\Omega) \end{aligned}$$

Generation of Complex Signals

- As the magnitude and phase of $Y(j\Omega)$ are an even and odd function, respectively, it follows from

$$Y(j\Omega) = -j X_p(j\Omega) + j X_n(j\Omega)$$

that $y(t)$ is also a real function

- Consider the complex signal $g(t)$:

$$g(t) = x(t) + j y(t)$$

Generation of Complex Signals

- The CTFT of $g(t)$ is thus given by

$$G(j\Omega) = X(j\Omega) + jY(j\Omega) = 2X_p(j\Omega)$$

- In other words, the complex signal $g(t)$, called an **analytic signal**, has only **positive** frequency components

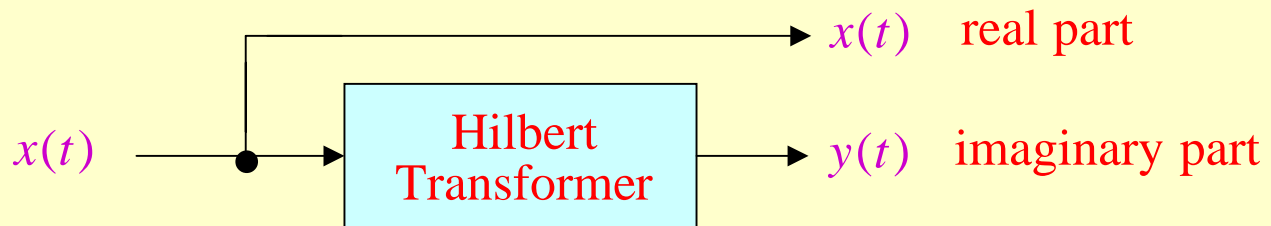

$$g(t) = x(t) + jy(t)$$

Modulation and Demodulation

- For efficient transmission of a low-frequency signal over a channel, it is necessary to transform the signal to a high-frequency signal by means of a modulation operation
- At the receiving end, the modulated high-frequency signal is demodulated to extract the desired low-frequency signal

Modulation and Demodulation

- There are 4 major types of modulation of analog signals:
 - (1) Amplitude modulation
 - (2) Frequency modulation
 - (3) Phase modulation
 - (4) Pulse amplitude modulation

Amplitude Modulation

- Amplitude modulation is conceptually simple
- Here, the amplitude of a high-frequency sinusoidal signal $A \cos(\Omega_o t)$, called the carrier signal, is varied by the low-frequency signal $x(t)$, called the modulating signal
- Process generates a high-frequency signal, called modulated signal, $y(t)$ given by:

$$y(t) = Ax(t) \cos(\Omega_o t)$$

Amplitude Modulation

- Thus, amplitude modulation can be implemented by forming the **product** of the modulating signal with the carrier signal
- **To demonstrate the frequency translating property, let**

$$x(t) = \cos(\Omega_1 t)$$

where

$$\Omega_1 \ll \Omega_0$$

Amplitude Modulation

- Then

$$\begin{aligned}y(t) &= A \cos(\Omega_1 t) \cdot \cos(\Omega_o t) \\ &= \frac{A}{2} \cos((\Omega_o + \Omega_1)t) \frac{A}{2} \cos((\Omega_o - \Omega_1)t)\end{aligned}$$

- The CTFT of $Y(j\Omega)$ of $y(t)$ is given by

$$Y(j\Omega) = \frac{A}{2} X(j(\Omega - \Omega_o)) + \frac{A}{2} X(j(\Omega + \Omega_o))$$

where $X(j\Omega)$ is the CTFT of $x(t)$

Amplitude Modulation

- Spectra of the modulating signal $x(t)$ and the modulated signal $y(t)$ are shown below

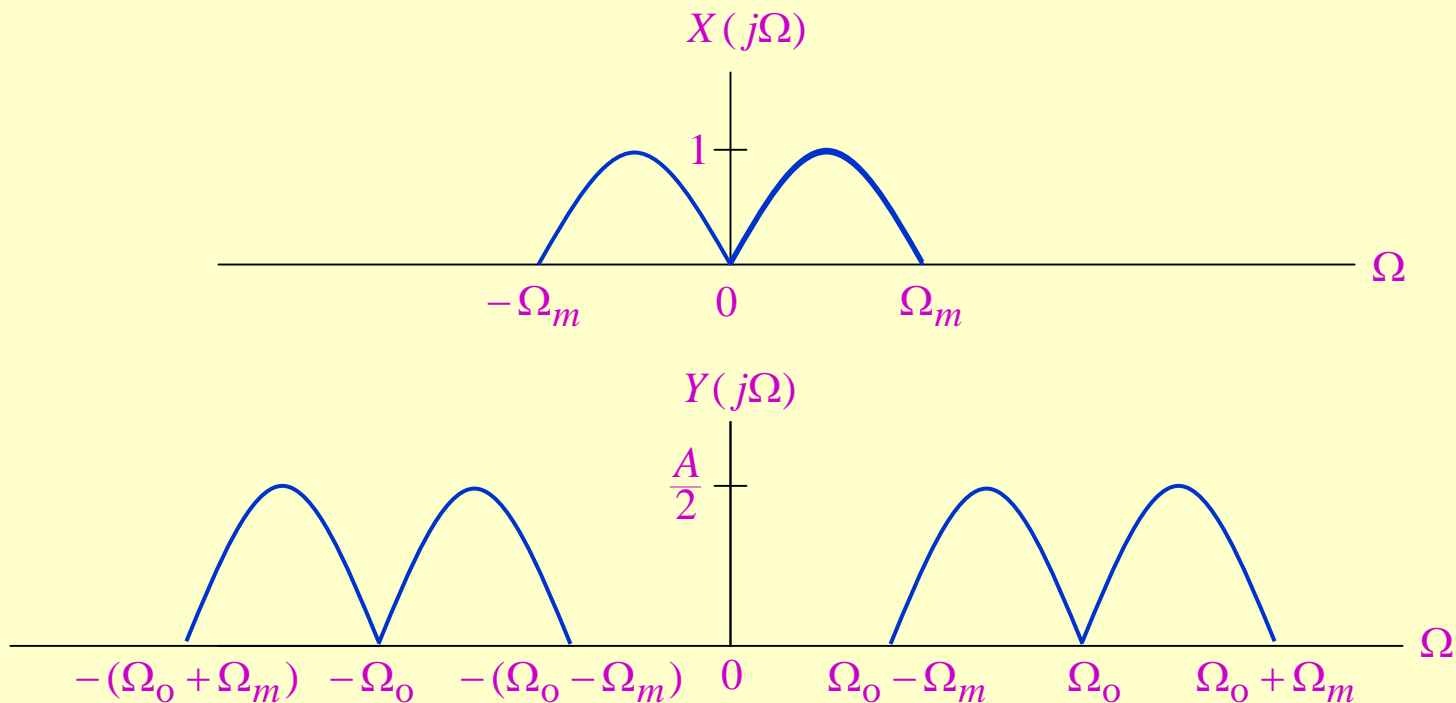

Amplitude Modulation

- As can be seen from the figures on the previous slide, $y(t)$ is a bandlimited high-frequency signal with a bandwidth of $2\Omega_m$ centered at Ω_o
- The portion of the amplitude-modulated signal between Ω_o and $\Omega_o + \Omega_m$ is called the **upper sideband**, whereas, the portion of the amplitude-modulated signal between Ω_o and $\Omega_o - \Omega_m$ is called the **lower sideband**

Amplitude Modulation

- Because of the generation of two sidebands and the absence of a carrier component in the modulated signal, the process is called double-sideband suppress carrier (DSB-SC) modulation
- The demodulation of $y(t)$ to recover $x(t)$ is carried out in two stages

Amplitude Modulation

- First, $y(t)$ is multiplied with a sinusoidal signal of the same frequency as the carrier:

$$\begin{aligned} r(t) &= y(t) \cos \Omega_0 t = Ax(t) \cos^2 \Omega_0 t \\ &= \frac{A}{2} x(t) + \frac{A}{2} x(t) \cos(2\Omega_0 t) \end{aligned}$$

- The result indicates that $r(t)$ is composed of $x(t)$ scaled by a factor $1/2$ and an amplitude-modulated signal with a carrier frequency $2\Omega_0$

Amplitude Modulation

- The spectrum $R(j\Omega)$ of $r(t)$ is shown below

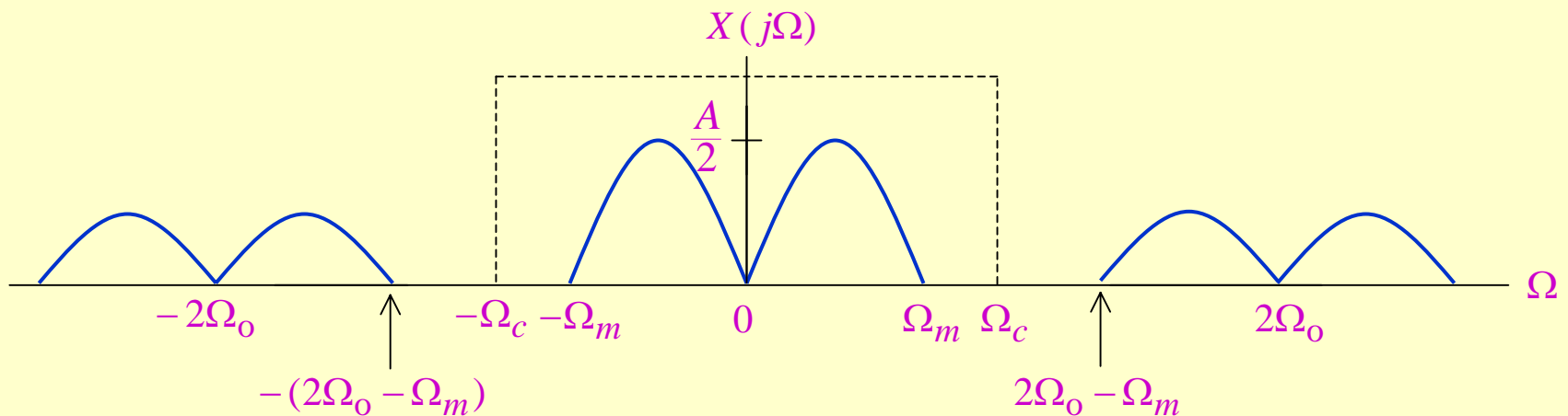

Amplitude Modulation

- Thus $x(t)$ can be recovered from $r(t)$ by passing it through a **lowpass filter** with a cutoff frequency at Ω_c satisfying the relation $\Omega_m < \Omega_c < 2\Omega_o - \Omega_m$
- The modulation and demodulation schemes are as shown below:

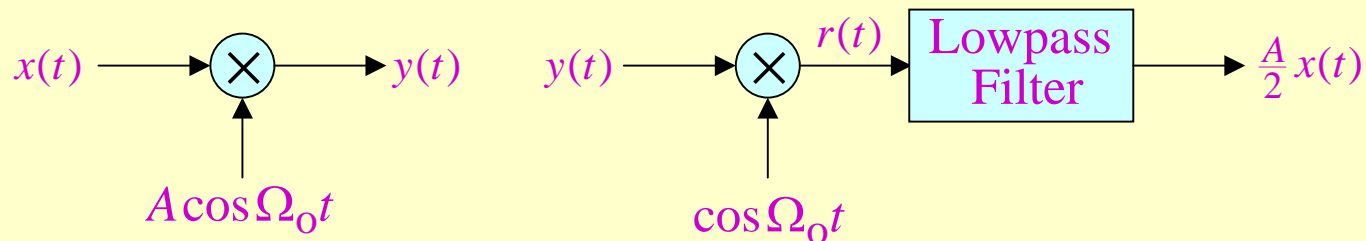

Amplitude Modulation

- In general, it is difficult to ensure that the demodulating sinusoidal signal has a frequency identical to that of the carrier
- To get around the above problem, the modulation process is modified so that the transmitted signal includes the carrier signal

Amplitude Modulation

- This is achieved by redefining the amplitude modulation operation as follows:

$$y(t) = A[1 + m x(t)] \cos(\Omega_0 t)$$

where m is a number chosen to ensure that $[1 + m x(t)]$ is positive for all t

- As the carrier is also present in the modulated signal, the process is called double-sideband (DSB) modulation

Amplitude Modulation

- Figure below shows the waveforms of a modulating sinusoidal signal of frequency 20 Hz and the amplitude-modulated carrier with a carrier frequency 400 Hz obtained using the DSB modulation scheme and $m = 0.5$

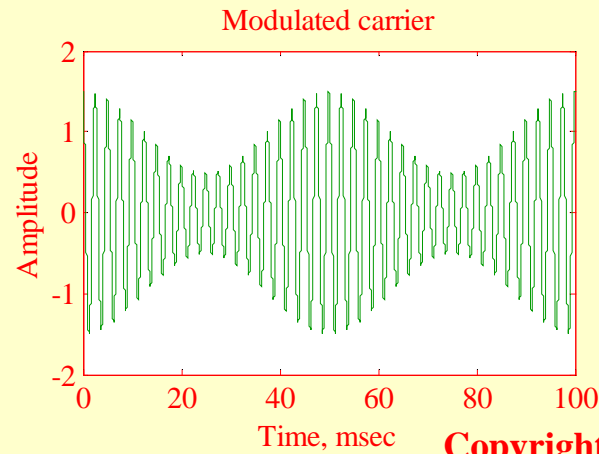
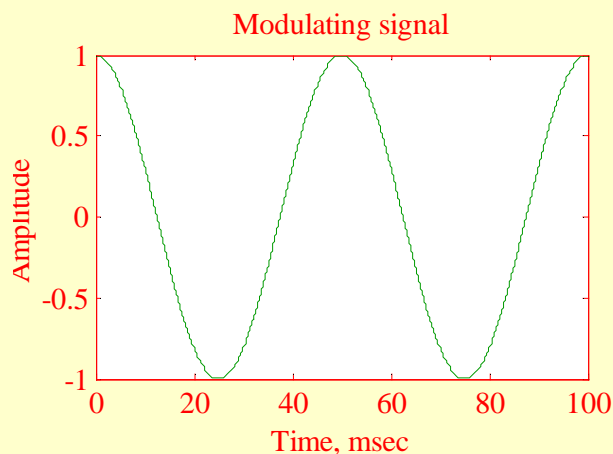

Amplitude Modulation

- In the case of the conventional DSB amplitude modulation scheme, the modulated signal has a bandwidth of $2\Omega_m$, whereas the bandwidth of the modulating signal is Ω_m
- To increase the capacity of the transmission medium, either the upper sideband or the lower sideband of the modulated signal is transmitted

Amplitude Modulation

- The corresponding procedure is called **single-sideband (SSB) modulation**, a possible implementation of which is shown below

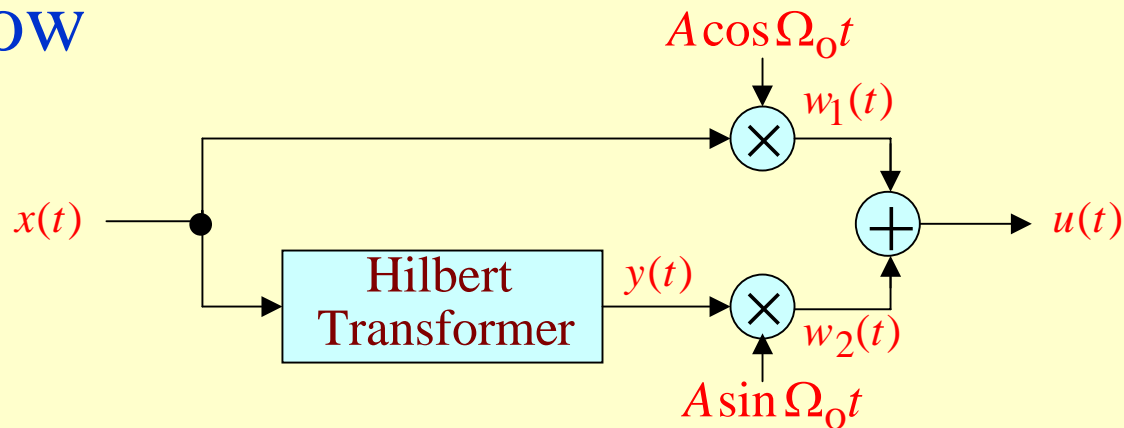

- The spectra of pertinent signals in the SSB modulation scheme are shown in the next slide

Amplitude Modulation

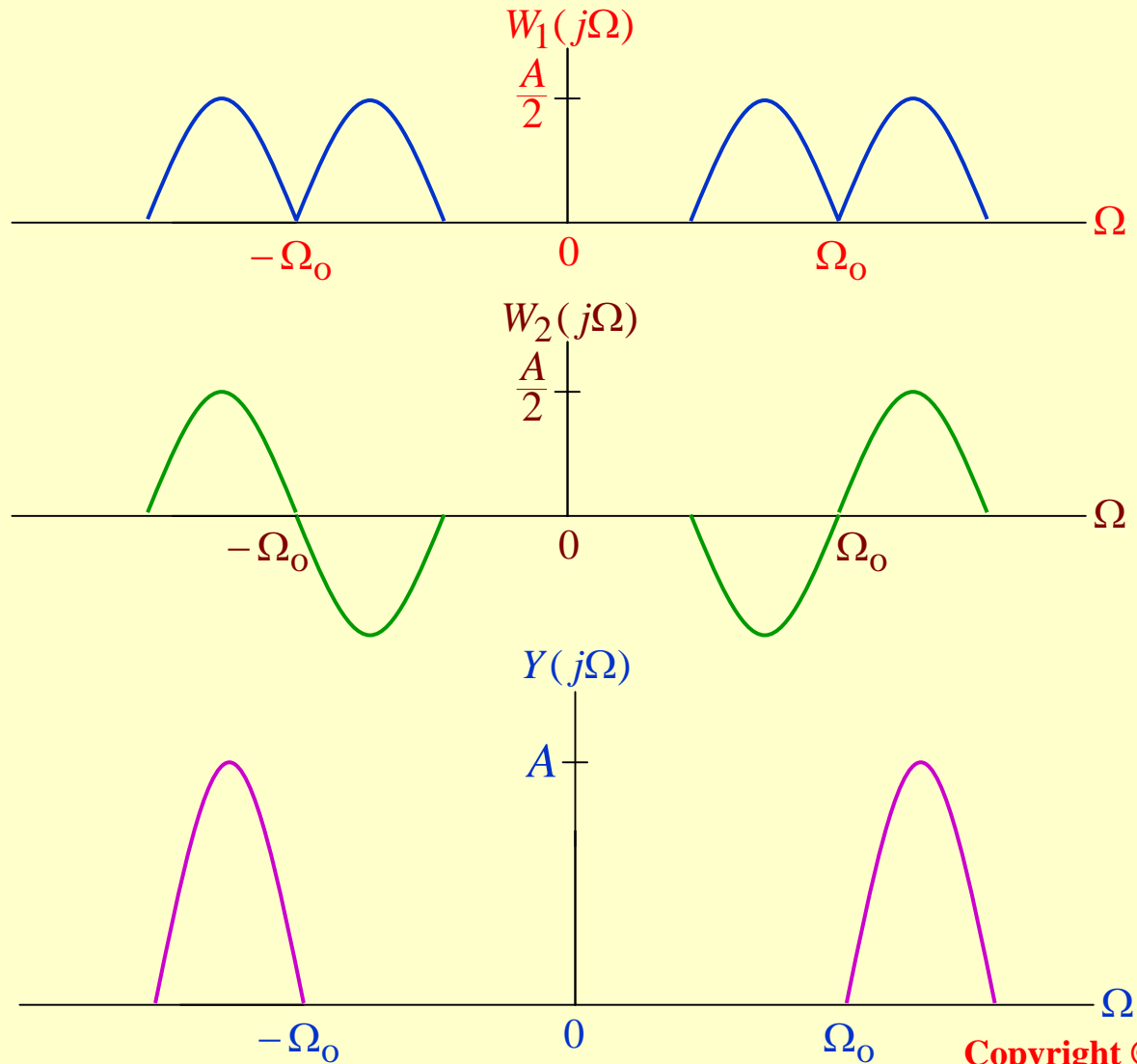

Quadrature Amplitude Modulation

- The DSB amplitude modulation is half as efficient as SSB amplitude modulation
- The quadrature amplitude modulation (QAM) method uses DSB modulation to modulate two different signals so that they both occupy the same bandwidth
- Hence, QAM takes up as much bandwidth as the SSB method

Quadrature Amplitude Modulation

- Consider two bandlimited signals $x_1(t)$ and $x_2(t)$ with a bandwidth of Ω_m as indicated below

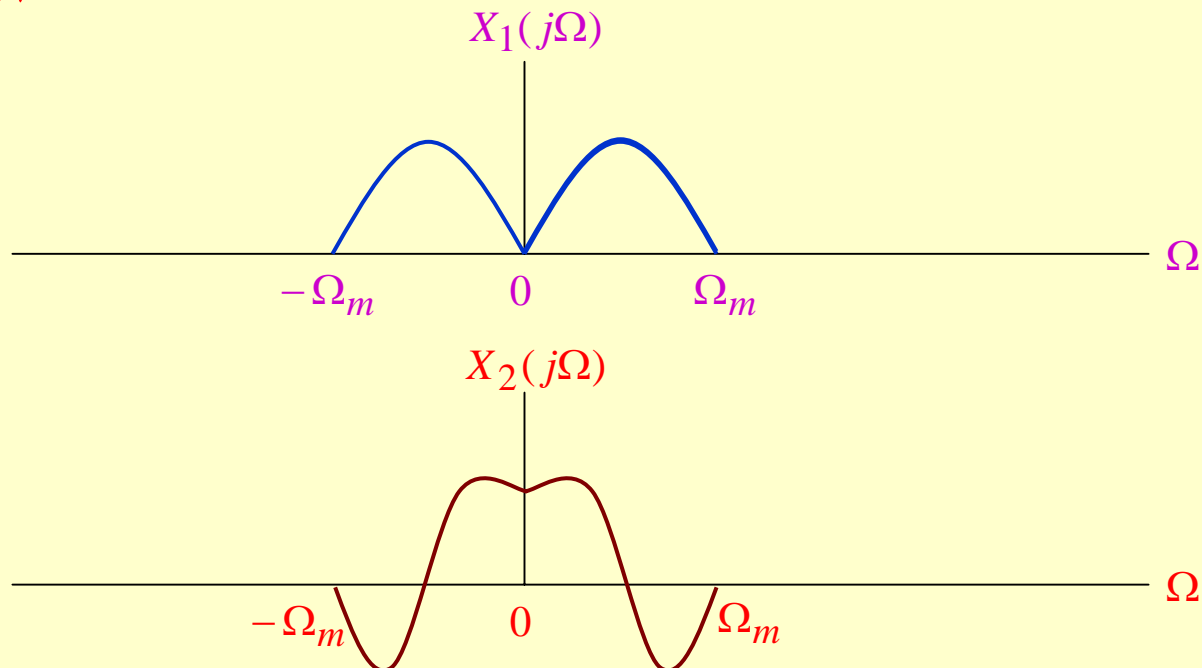

Quadrature Amplitude Modulation

- The two modulating signals are individually modulated by the two carrier signals $A\cos(\Omega_0 t)$ and $A\sin(\Omega_0 t)$, respectively, and are summed, resulting in

$$y(t) = Ax_1(t)\cos(\Omega_0 t) + Ax_2(t)\sin(\Omega_0 t)$$

- The two carrier signals have the same carrier frequency Ω_0 but have a phase difference of 90°

Quadrature Amplitude Modulation

- The carrier $A \cos(\Omega_o t)$ is called the in-phase component and the carrier $A \sin(\Omega_o t)$ is called the quadrature component
- The spectrum $Y(j\Omega)$ of the composite signal $y(t)$ is given by

$$Y(j\Omega) = \frac{A}{2} \{ X_1(j(\Omega - \Omega_o)) + X_1(j(\Omega + \Omega_o)) \} \\ + \frac{A}{2j} \{ X_2(j(\Omega - \Omega_o)) - X_2(j(\Omega + \Omega_o)) \}$$

Quadrature Amplitude Modulation

- $y(t)$ is seen to occupy the same bandwidth as the modulated signal obtained by a DSB modulation
- To recover $x_1(t)$ and $x_2(t)$, $y(t)$ is multiplied by both the in-phase and the quadrature components of the carrier separately, resulting in

$$r_1(t) = y(t) \cos(\Omega_0 t)$$

$$r_2(t) = y(t) \sin(\Omega_0 t)$$

Quadrature Amplitude Modulation

- Substituting the expression for $y(t)$ in both of the last two equations, we obtain after some algebra

$$r_1(t) = \frac{A}{2} x_1(t) + \frac{A}{2} x_1(t) \cos(2\Omega_0 t) + \frac{A}{2} x_2(t) \sin(2\Omega_0 t)$$

$$r_2(t) = \frac{A}{2} x_2(t) + \frac{A}{2} x_1(t) \sin(2\Omega_0 t) - \frac{A}{2} x_2(t) \cos(2\Omega_0 t)$$

- Lowpass filtering of $r_1(t)$ and $r_2(t)$ by filters with a cutoff at Ω_m yields $x_1(t)$ and $x_2(t)$

Quadrature Amplitude Modulation

- The QAM modulation and demodulation schemes are shown below

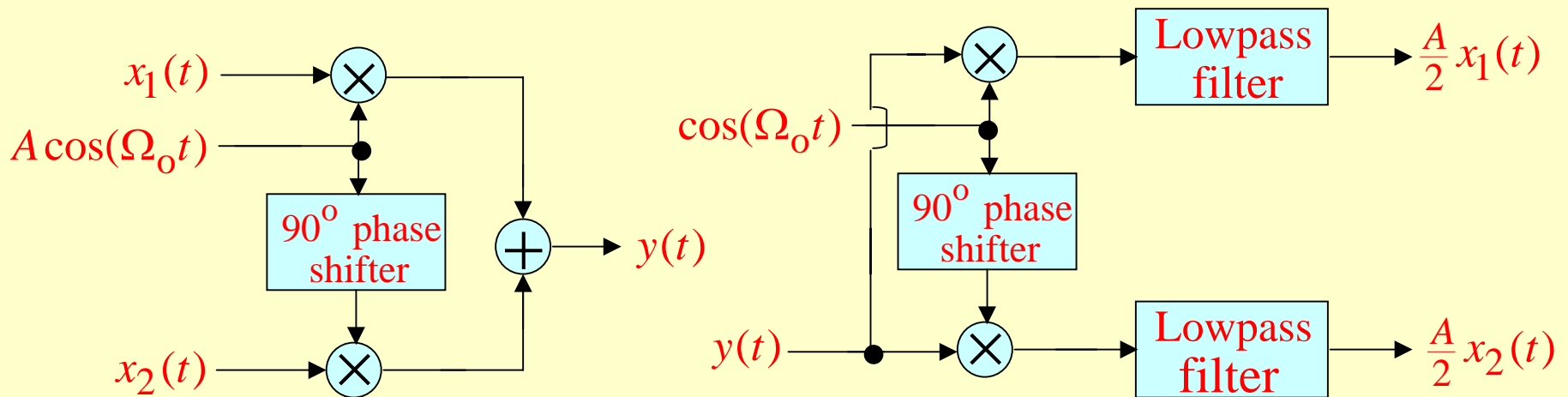

Multiplexing and Demultiplexing

- For an efficient utilization of a wideband transmission channel, many narrow-bandwidth low-frequency signals are combined for a composite wideband signal that is transmitted as a single signal
- The process of combining the low-frequency signals is called multiplexing

Multiplexing and Demultiplexing

- Multiplexing is implemented to ensure that a replica of each of the original narrow-bandwidth low-frequency signal can be recovered at the receiving end
- The recovery process of the low-frequency signals is called demultiplexing

Multiplexing and Demultiplexing

- One method of combining different voice signals in a telephone communication system is the frequency-division multiplexing (FDM) scheme
- Here, each voice signal, typically bandlimited to a low-frequency band of width Ω_m , is frequency-translated into a higher frequency band using the amplitude modulation method

Multiplexing and Demultiplexing

- The carrier frequency of adjacent amplitude-modulated signals is separated by Ω_o , where $\Omega_o > 2\Omega_m$ to ensure that there is no overlap in the spectra of the individual modulated signals after they are added to form the baseband composite signal
- The composite signal is then modulated onto the main carrier developing the FDM signal and transmitted

Multiplexing and Demultiplexing

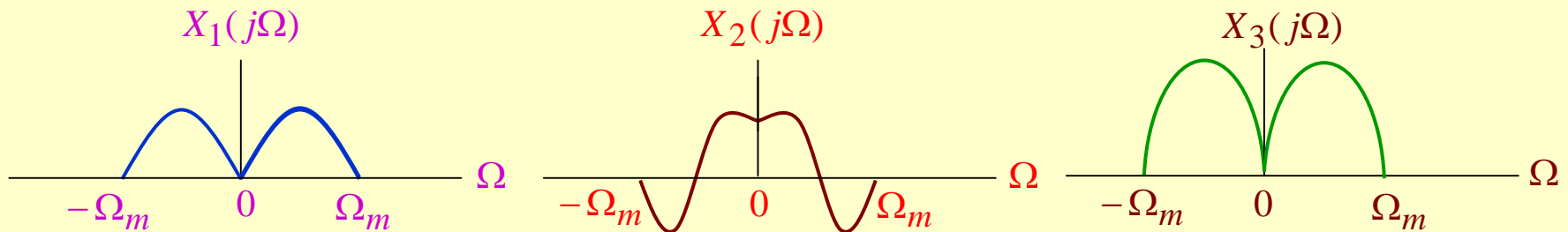

Spectra of the low-frequency signals

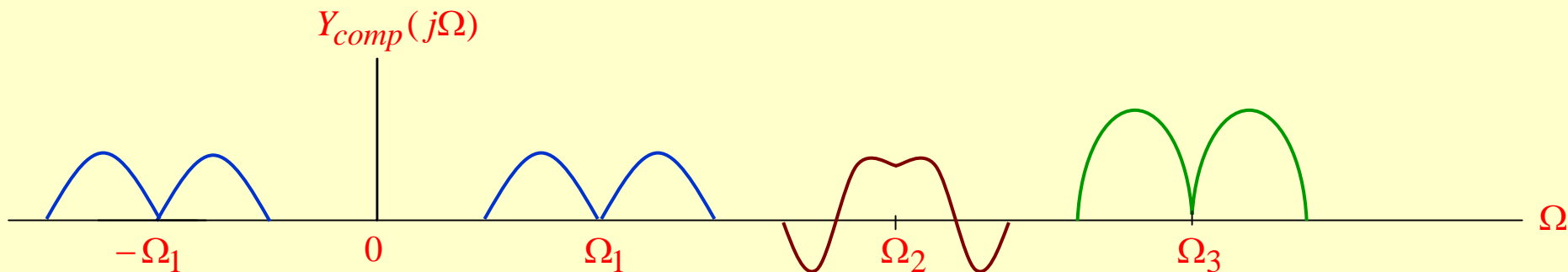

Spectra of the modulated composite signal

Multiplexing and Demultiplexing

- At the receiving end, the composite baseband signal is first recovered from the FDM signal by demodulation
- Then each individual frequency-translated signal is demultiplexed by passing the composite signal through a bank of bandpass filters

Multiplexing and Demultiplexing

- The center frequency of each bandpass filter has a value same as that of its carrier frequency and bandwidth slightly greater than $2\Omega_m$
- The output of each bandpass filter is then demodulated to recover a scaled replica of its corresponding voice signal

Advantages of DSP

- Absence of drift in the filter characteristics
 - Processing characteristics are fixed, e.g. by binary coefficients stored in memories
 - Thus, they are independent of the external environment and of parameters such as temperature
 - Aging has no effect

Advantages of DSP

- Improved quality level
 - Quality of processing limited only by economic considerations
 - Arbitrarily low degradations achieved with desired quality by increasing the number of bits in data/coefficient representation
 - An increase of 1 bit in the representation results in a 6 dB improvement in the SNR

Advantages of DSP

- **Reproducibility**
 - Component tolerances do not affect system performance with correct operation
 - No adjustments necessary during fabrication
 - No realignment needed over lifetime of equipment

Advantages of DSP

- Ease of new function development
 - Easy to develop and implement adaptive filters, programmable filters and complementary filters
 - Illustrates flexibility of digital techniques

Advantages of DSP

- **Multiplexing**
 - Same equipment can be shared between several signals, with obvious financial advantages for each function
- **Modularity**
 - Uses standard digital circuits for implementation

Advantages of DSP

- Total single chip implementation using VLSI technology
- No loading effect

Limitations of DSP

- **Lesser Reliability**
 - Digital systems are active devices, and thus use more power and are less reliable
 - Some compensation is obtained from the facility for automatic supervision and monitoring of digital systems

Limitations of DSP

- Limited Frequency Range of Operation
 - Frequency range technologically limited to values corresponding to maximum computing capacities that can be developed and exploited
- Additional Complexity in the Processing of Analog Signals
 - A/D and D/A converters must be introduced adding complexity to overall system

DSP Application Examples

- Cellular Phone
- Discrete Multitone Transmission
- Digital Camera
- Digital Sound Synthesis
- Signal Coding & Compression
- Signal Enhancement

Cellular Phone Block Diagram

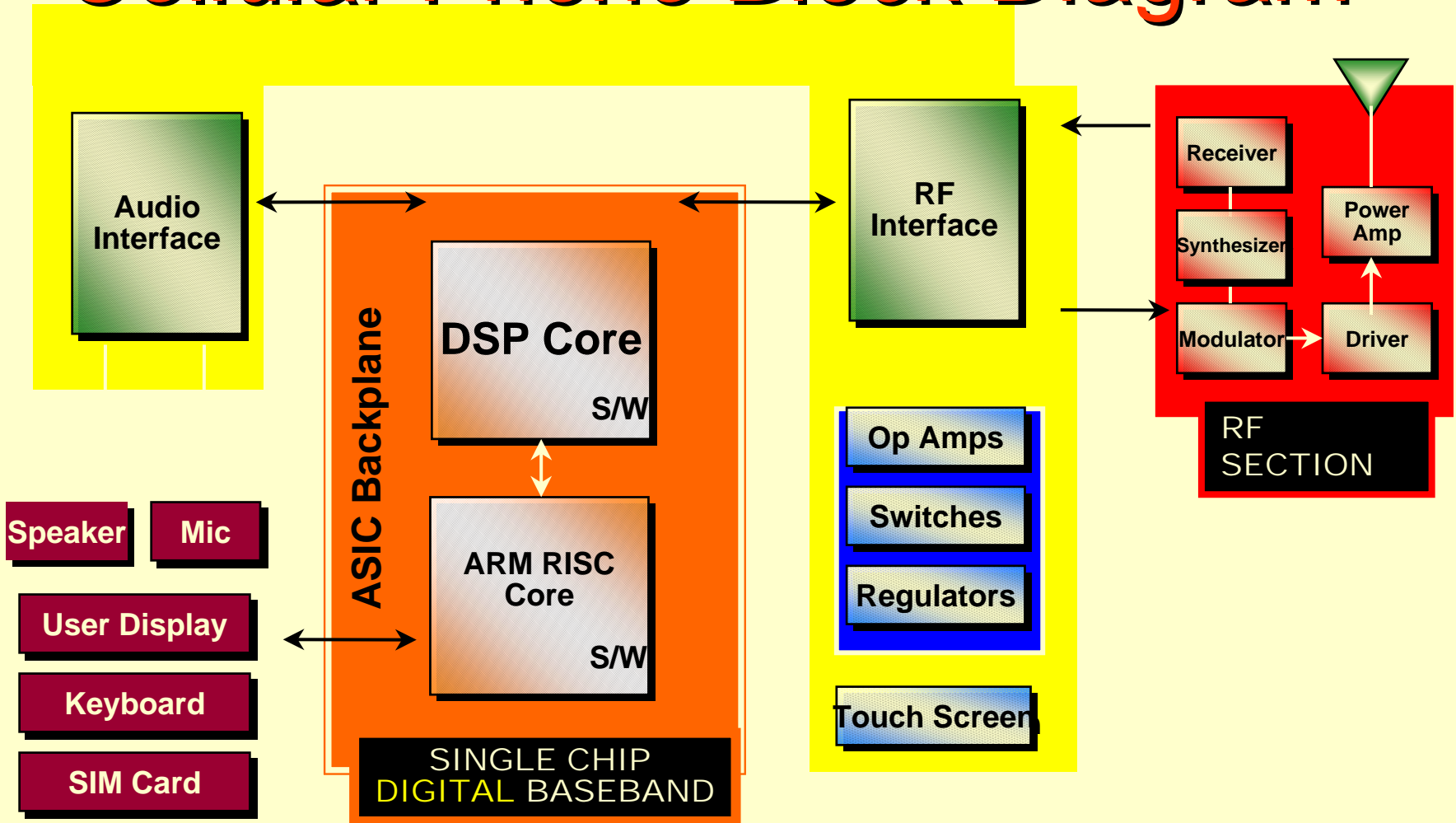

Cellular Phone Baseband System on a Chip

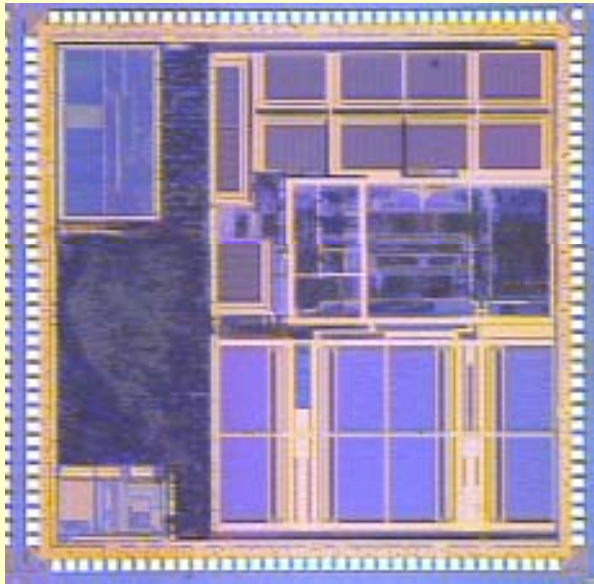

- **100-200 MHz DSP + MCU**
- **ASIC Logic**
- **Dense Memory**
- **Analog**

Discrete Multitone Transmission (DMT)

- Core technology in the implementation of the asymmetric digital subscriber line (ADSL) and very-high-rate digital subscriber line (VDSL)
- Closely related to: Orthogonal frequency-division multiplexing (OFDM)

ADSL

- A local transmission system designed to simultaneously support three services on a single twisted-wire pair:
 - Data transmission downstream (toward the subscriber) at bit rates of upto 9 Mb/s
 - Data transmission upstream (away from the subscriber) at bit rates of upto 1 Mb/s
 - Plain old telephone service (POTS)

ADSL

- Band-allocations for an FDM-based ADSL system

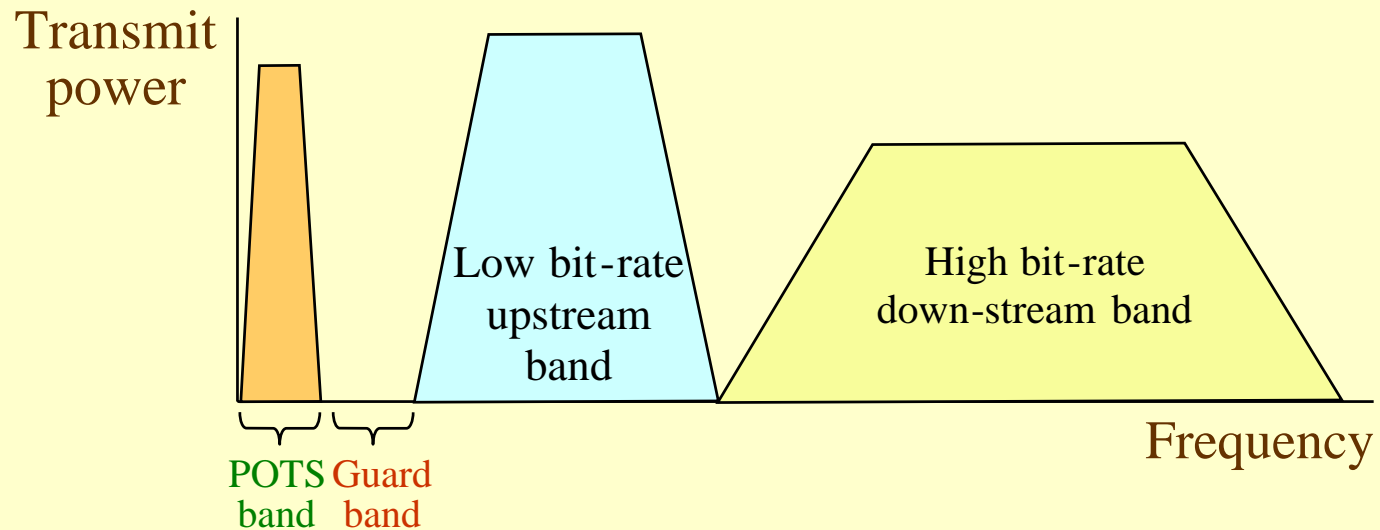

ADSL

- Asymmetry in the frequency band allocation:
 - to bring movies, television, video catalogs, remote CD-ROMs, corporate LANs, and the Internet into homes and small businesses

VDSL

- Optical network emanating from twisted pair provides data rates of 13 to 26 Mb/s downstream and 2 to 3 Mb/s upstream over short distances less than about 1 km
- Allows the delivery of digital TV, super-fast Web surfing and file transfer, and virtual offices at home

Discrete Multitone Transmission

- Advantages in using DMT for ADSL and VDSL
 - The ability to maximize the transmitted bit rate
 - Adaptivity to changing line conditions
 - Reduced sensitivity to line conditions

OFDM

- Applications:
 - **Wireless communications** - an effective technique to combat multipath fading
 - **Digital audio broadcasting**
- Uses a fixed number of bits per subchannel while DMT uses loading for bit allocation

OFDM

- Basic differences with DMT architecture
 - Signal constellation encoder does not include a loading algorithm for bit allocation
 - In the transmitter, an **upconverter** included after the **D/A converter** to translate the transmitted frequency
 - In the receiver, a **downconverter** included before the **A/D converter** to undo the frequency translation

Digital Camera

- CMOS Imaging Sensor
 - Increasingly being used in digital cameras
 - Single chip integration of sensor and other image processing algorithms needed to generate final image
 - Can be manufactured at low cost
 - Less expensive cameras use single sensor with individual pixels in the sensor covered with either a red, a green, or a blue optical filter

Digital Camera

- Image Processing Algorithms
 - Bad pixel detection and masking
 - Color interpolation
 - Color balancing
 - Contrast enhancement
 - False color detection and masking
 - Image and video compression

Digital Camera

- Bad Pixel Detection and Masking

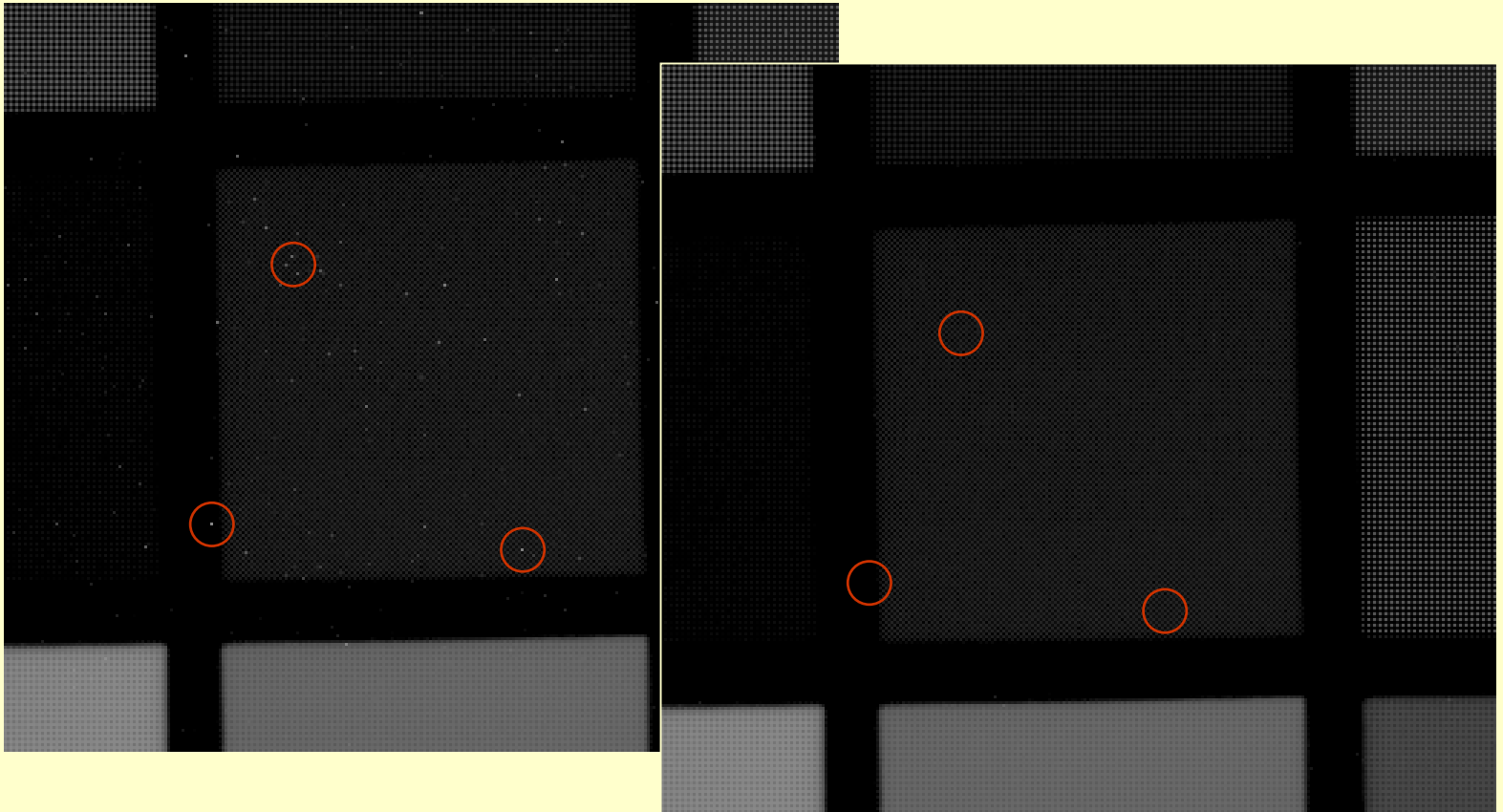

Digital Camera

- Color Interpolation and Balancing

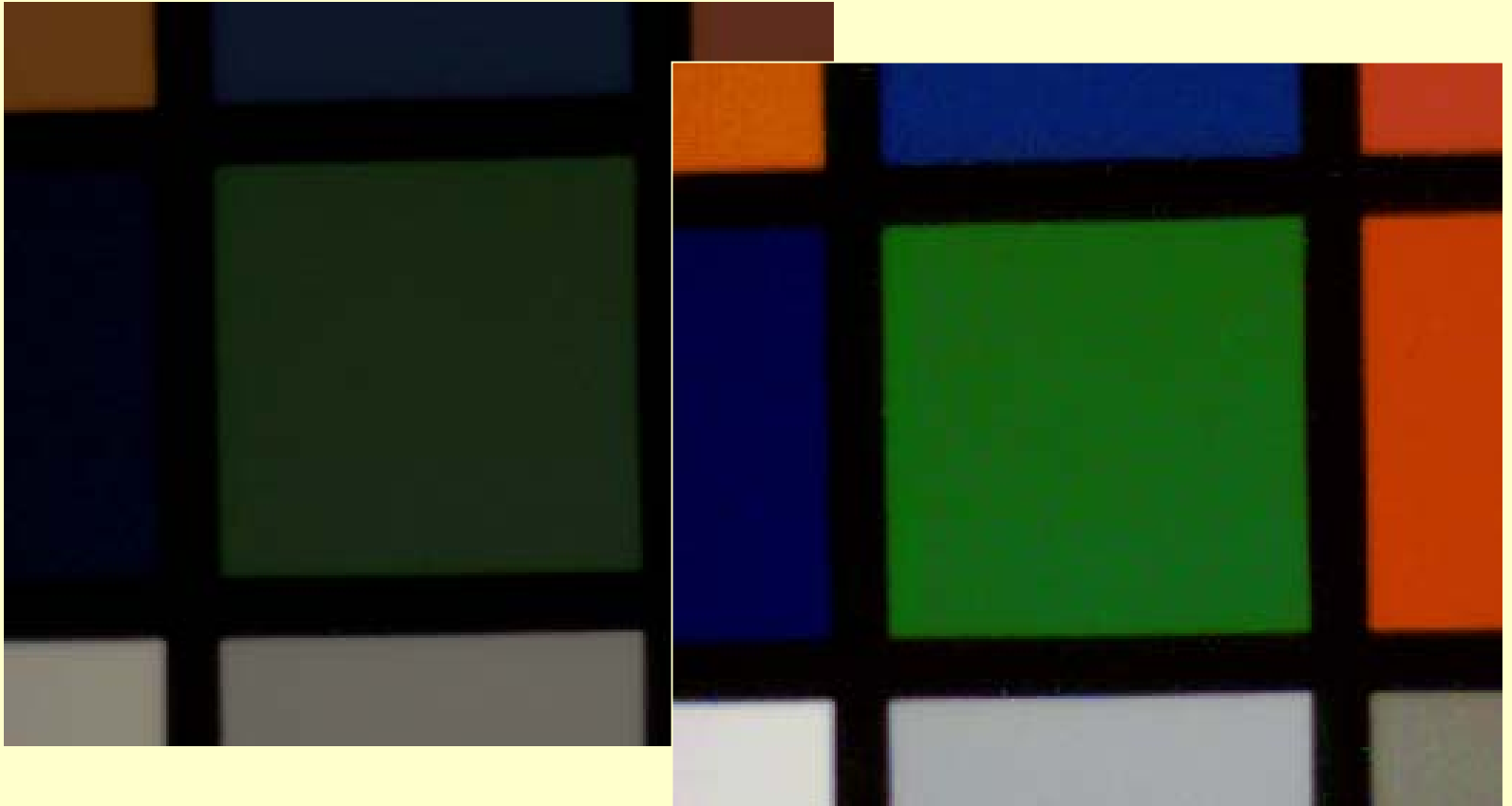

Digital Sound Synthesis

- Four methods for the synthesis of musical sound:
 - Wavetable Synthesis
 - Spectral Synthesis
 - Nonlinear Synthesis
 - Synthesis by Physical Modeling

Digital Sound Synthesis

- **Wavetable Synthesis**

- Recorded or synthesized musical events stored in internal memory and played back on demand
- Playback tools consists of various techniques for sound variation during reproduction such as **pitch shifting**, **looping**, **enveloping** and **filtering**
- Example: Giga Sampler 

Digital Sound Synthesis

- **Spectral Synthesis**
 - Produces sounds from frequency domain models
 - Signal represented as a superposition of basis functions with time-varying amplitudes
 - Practical implementation usually consist of a combination of **additive synthesis**, **subtractive synthesis** and **granular synthesis**
 - Example: Kawai K500 Demo 

Digital Sound Synthesis

- **Nonlinear Synthesis**



- **Frequency modulation method**: Time-dependent phase terms in the sinusoidal basis functions

- An inexpensive method frequently used in synthesizers and in sound cards for PC

- **Example**: Variation modulation index complex algorithm (Pulsar) 

Digital Sound Synthesis

- **Physical Modeling**

- Models the sound production method
- Physical description of the main vibrating structures by partial differential equations
- Most methods based on wave equation describing the wave propagation in solids and in air
- **Examples:** (CCRMA, Stanford)
 - Guitar with nylon strings 
 - Marimba 
 - Tenor saxophone 



Signal Coding & Compression

- Concerned with efficient digital representation of audio or visual signal for storage and transmission to provide maximum quality to the listener or viewer

Signal Compression Example

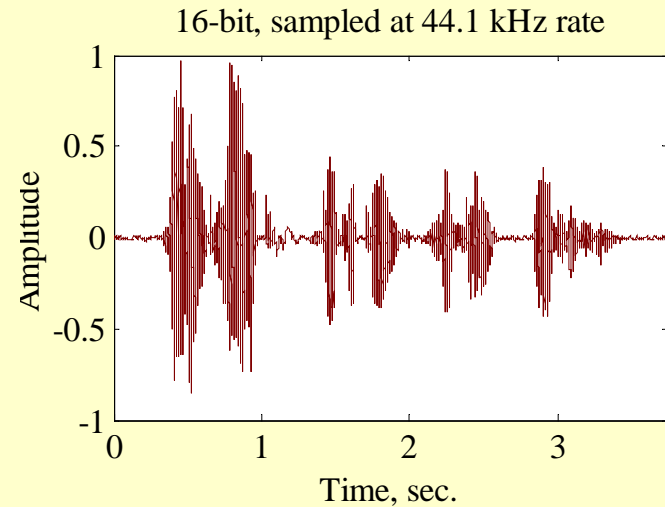
- Original speech 
Data size 330,780 bytes



- Compressed speech (GSM 6.10) 
 - Sampled at 22.050 kHz, Data size 16,896 bytes
- Compressed speech (Lernout & Hauspie CELP 4.8kbit/s) 
 - Sampled at 8 kHz, Data size 2,302 bytes

Signal Compression Example

- Original music 

Audio Format: PCM 16.000 kHz, 16 Bit
(Data size 66206 bytes)

- Compressed music 

Audio Format: GSM 6.10, 22.05 kHz
(Data size 9295 bytes)

Signal Compression Example

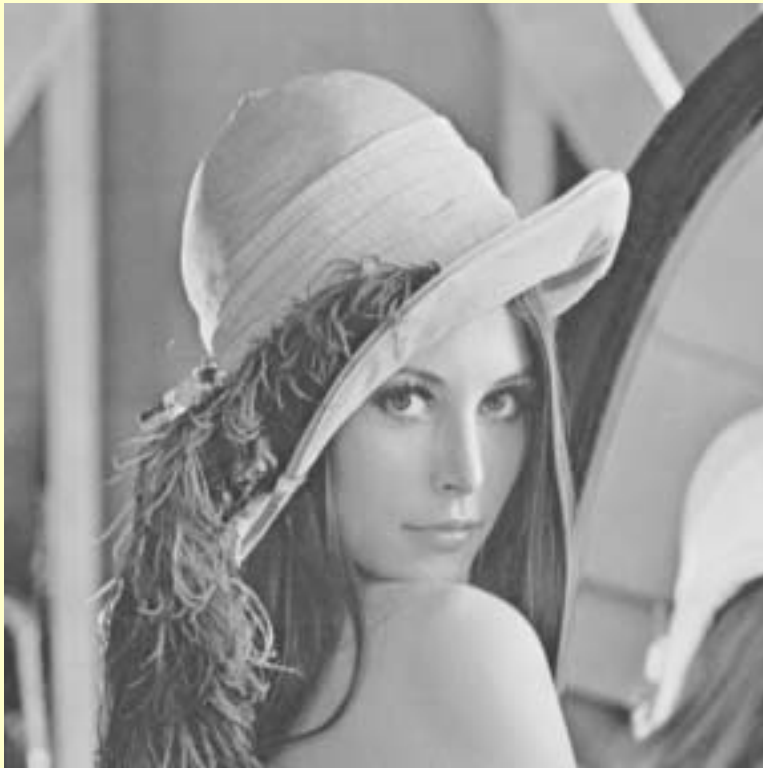

Original Lena
8 bits per pixel



Compressed Image
Average bit rate - 0.5 bits per pixel

Signal Enhancement

- **Purpose:** To emphasize specific signal features to provide maximum quality to the listener or viewer
- For speech signals, algorithms include removal of background noise or interference
- For image or video signals, algorithms include contrast enhancement, sharpening and noise removal

Signal Enhancement Example

- Noisy speech signal 
(10% impulse noise)

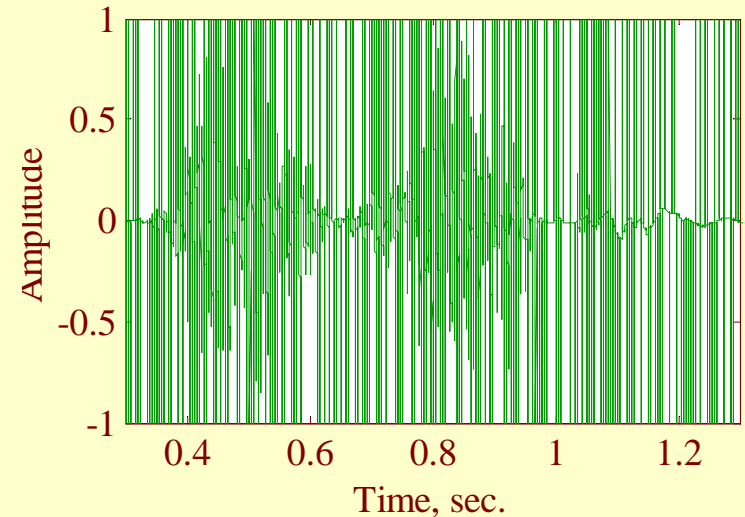

- Noise removed speech 

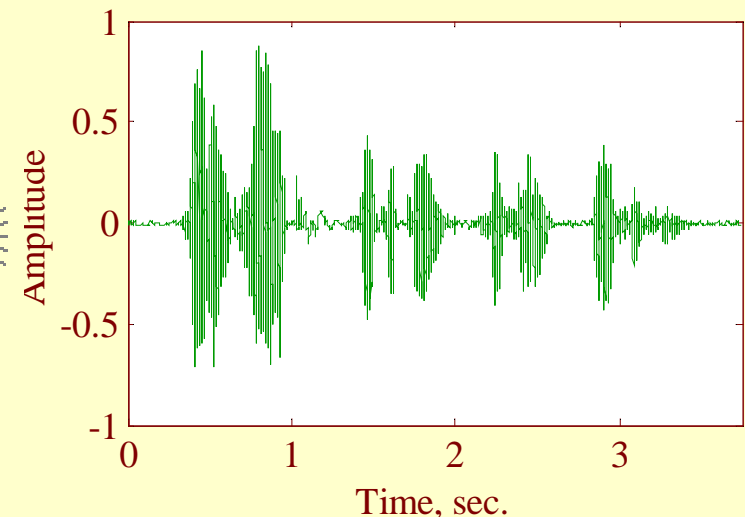

Signal Enhancement Example

EKG corrupted with
60 Hz interference

EKG after filtering with
a notch filter

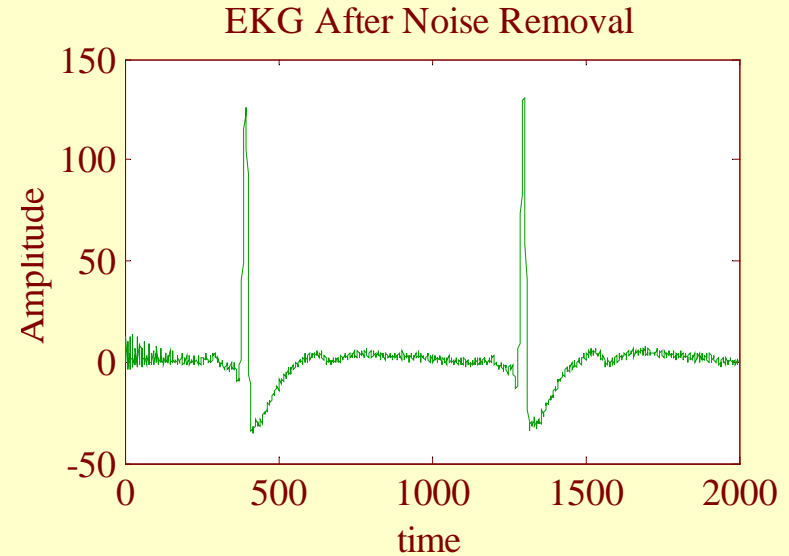
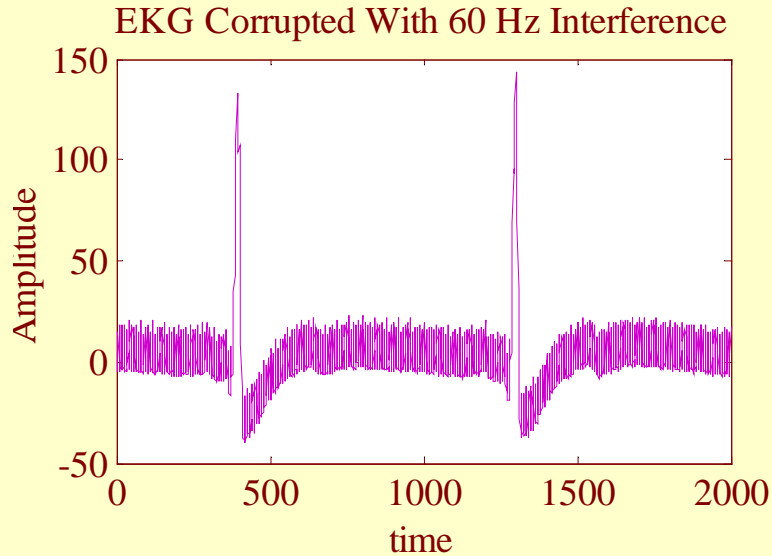

Signal Enhancement Example

- Original image and its contrast enhanced version



Original



Enhanced

Signal Enhancement Example

- Original image and its contrast enhanced version



Original



Enhanced

Signal Enhancement Example

- Noise corrupted image and its noise-removed version



20% pixels corrupted with additive impulse noise



Noise-removed version